



# Granule Maxi®



– large scale potwashing  
customised to your needs

**GRANULE MAXI® IS DEDICATED TO** medium sized and large kitchens such as:

- Restaurants/hotels using large numbers of mixed pots
- Hospital/health care kitchens
- Staff canteens
- Schools, universities
- Catering companies
- Food processing industries...

Most of our Granule Maxi® customers prepare up to 4 000 meals a day. This limit is not fixed and depend more on how the food is prepared and distributed than on the actual number of portions. Our customers are pleasantly surprised when it comes to both time and cost savings. The machine ensures that clean pots are returned to the kitchen fast. Moreover, consumption of detergent, water and energy are reduced.

## Powerful, versatile, high capacity

### High capacity

“No time to waste!” Many of our customers want to improve workflow in their kitchens to make them more efficient and flexible. The Granule Maxi® is a high capacity machine: you can wash up to 192 x GN 1/1 containers per hour. Clean pots are returned more quickly to the kitchen. Moreover, the operator can do other tasks while the machine is running a wash cycle.

### Multipurpose

Do you need to wash both small and large kitchen utensils? Do you use gastronorms, pans, ceramic bowls and plastic trays as well as pots and pans? Whatever the type, size or shape of your utensils, the Granule Maxi® will wash them! Many accessories are available to help you clean a wide variety of kitchen tools.

# Find the system that meets your needs

Our customers have neither the same kitchen sizes nor the same needs. We have designed 3 different versions of the Granule Maxi® to get the full benefit from the machine.

• **Granule Maxi® Compact System** – Is space an issue in your kitchen? Then you should know that the Granule Maxi® Compact System provides you with the highest wash capacity per square metre. This version is equipped with a retractable multicassette which, with the aid of a few accessories, can deal with all the pots and pans in your kitchen. Pots are easily loaded directly into the lower part of the cassette.

• **Granule Maxi® Flow System** – Would you like to enhance efficiency and speed up the flow of your pots? The Granule Maxi® Flow System is equipped with loose cassettes and a cassette trolley. This means that one cassette can be washed while another is filled or emptied. When capacity requirements increase, it is easy to expand the Granule Maxi® Flow System with as many cassettes as required.

• **Granule Maxi® FreeFlow System** – Would you like to have full flexibility and adaptability in your potwashing area? You can both save space and reduce the distance walked during the day because this machine's multicassette is loaded directly while hanging on the cassette trolley. One big advantage is the option of loading pots into the cassette in different parts of the kitchen before transporting them to the potwashing machine using the trolley. After the wash cycle, you then unload the pots directly at the locations where they are stored. The Granule Maxi® FreeFlow System is equipped with two cassettes and two cassette trolleys and can be expanded as required.

**Compact System**



**Flow System**

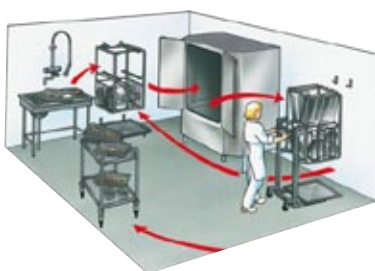

**FreeFlow System**

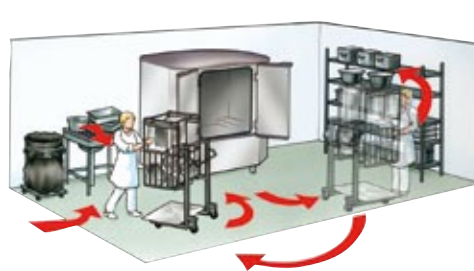

## e for ...

### ... efficiency

GRANULDISK® offers the highest level of efficiency to one of the most thankless areas of the kitchen.

### ... environment

Save on nature's resources with GRANULDISK®; cut your energy, water and detergent consumption by half\*.

### ... ensured hygiene

A temperature of 72 °C on the surface of washed items guarantees hygienically clean pots and pans.

### ... ergonomomy

Enjoy a dramatically improved working environment and lighter working day.



## Let Granules handle the dirty work

### ... extra time

Spend 1 hour cleaning 192 GN 1/1 with Granule Maxi® - instead of more than 1 day cleaning them by hand.

### ... economy

It pays to invest in a GRANULDISK® machine - faster than you might think! Our customers often have a return on investment (ROI) that is well within 24 months.



... **learn more** about our machine range, all the green savings and GRANULDISK® ware washing solutions at [www.granuldisk.com](http://www.granuldisk.com) or in the collected GRANULDISK® brochure.

\* In comparison with 4 hours of manual potwashing/day.

# Technical specifications

Weight	674 kg (filled machine)
Tank volume	165 litres
Granule amount	16 kg
Wash power	10 % Granule concentration
Wash water temperature	65 °C
Rinse water temperature	85 °C
Rinse water volume (litres/ wash programme)	Eco programme: 7 litres Short/Normal programme: 14 litres To achieve 3600 HUE according to NSF/ANSI 3 - 2007.
Wash programmes	Eco 2 min. 30 s. Short 4 min. 40 s. Normal 6 min. 40 s. Programmes without Granules are 1 min. shorter
Time for steam reduction	1 minute (Short/Normal Programme)
Loading volume	450 litres w 540 x h 1060 x d 680 (mm)
Capacity	8 GN 1/1, 200 mm deep, or 16 GN 1/2, 200 mm deep containers or the equivalent in other utensils.
Max capacity/h Freeflow/ Flow/Compact	192 GN 1/1
Normal capacity/h Freeflow/Flow/Compact	160/144/136 GN 1/1

\* Not in use simultaneously

Voltage**	3 ~ 400 V 50 Hz (standard) **Other Voltage available on request
Fuse	40 A (Steam heating option 20 A, c.w option 50 A)
Maximum power	21 kW (steam 5 kW, c.w option 29 kW)
Wash pump motors	2 x 2.2 kW (2 x 3.0 kW 575 V)
Rinse pump motor	0.37 kW
Wash/Rinse tank element*	16 kW (c.w option 24 kW)
Encapsulation class	IP 55
Hot water connection	1/2" (DN 15), 55-65 °C, 3-7 °dH
Water pressure/flow h.w.	1-6 bar /25 litres/min.
Cold water connection	1/2" (DN 15), 3-7 °dH
Water pressure/flow c.w	3-6 bar /15 litres/min
Detergent and rinse agent	24 and 230 VAC signals in separate connection box.
Ventilation	Recommended capacity Machine without steam reduction: 700 m³/h Machine with steam reduction: 200 m³/h
Outflow	Pipe Ø 32 mm
Drain	Required capacity 100 litres/minute The machine should not be placed directly above the drain.

## Accessories



### GD 975 MULTI CASSETTE FOR 8 GN 1/1

For pots, pans, bowls, dough hooks, etc. and all types of 1/1 and 2/1 GN containers, stacked directly in the lower part of the cassette without accessories.  
(ref. no. 14469)



### GD 956 DIVIDER FOR CONTAINERS (GN 1/9 TO 2/3)

The divider is placed halfway or two thirds of the way between the existing guides in the cassette. One divider/cassette is always included in the machine delivery.  
(ref. no. 19313)



### GD 950 MULTIPURPOSE HOLDER

For containers with fixed handles, small to medium pots and saucepans, buckets or other utensils that can be hung on a hook. The holder is placed in one of the cassette's upper guides.  
(ref. no. 10972)



### GD 951 UTENSIL HOLDER

For ladles, whisks, beaters and similar utensils. The holder is placed in one of the upper guides in the cassette.  
(ref. no. 10362)

- Capacity: max 22 utensils



### GD 953 LID HOLDER

The insert for washing lids, trays or similar utensils. The holder is placed in the lower guides of the cassette.  
(ref. no. 10950)



### GD 954 HOLDER FOR GN 1/3, 1/6, 1/9

Holder with guides in three rows for small containers. The holder is placed in one of the four cassette guides.  
(ref. no. 10948)

With one holder each row in the holder can take one of the following combination of utensils;

- 2 x GN 1/3 and
- 4 x GN 1/6 and
- 6 x GN 1/9



### GD 955 HOLDER FOR SMALL POTS AND BOWLS

Holder for small pots and bowls or similar items that cannot be hung or are too small to be loaded directly into the multicassette. (ref. no. 10004)

- 3 x small pots/bowls; ca Ø 220 mm (max depth 175 mm)



### GD 651 NET BASKET FOR LADLES, WHISKS AND BEATERS

Net basket for ladles, beaters and other small things. (ref. no. 13493)

- Tools with a max length of 550 mm

More accessories available, learn more at [www.granuldisk.com](http://www.granuldisk.com)



PowerGranules® have been specially developed to be used with GRANULDISK® products. Not only will they extend the lifespan of your machine, but also make your pots and pans visibly and hygienically clean!

PowerGranules are made from a material which has been approved for use in contact with food, and are also harmless to ingest. The unique mix of sizes and material composition also gives better removal rates, leaving you with exceptional results!

8 kg bucket: ref.no 19833      20 kg bucket: ref.no 19834





# Installation drawings

(mm)

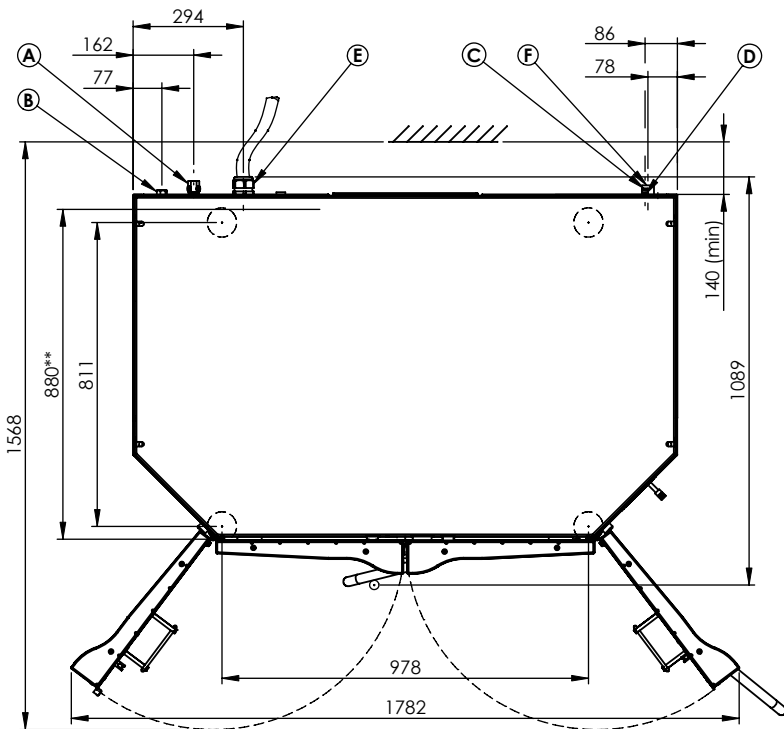
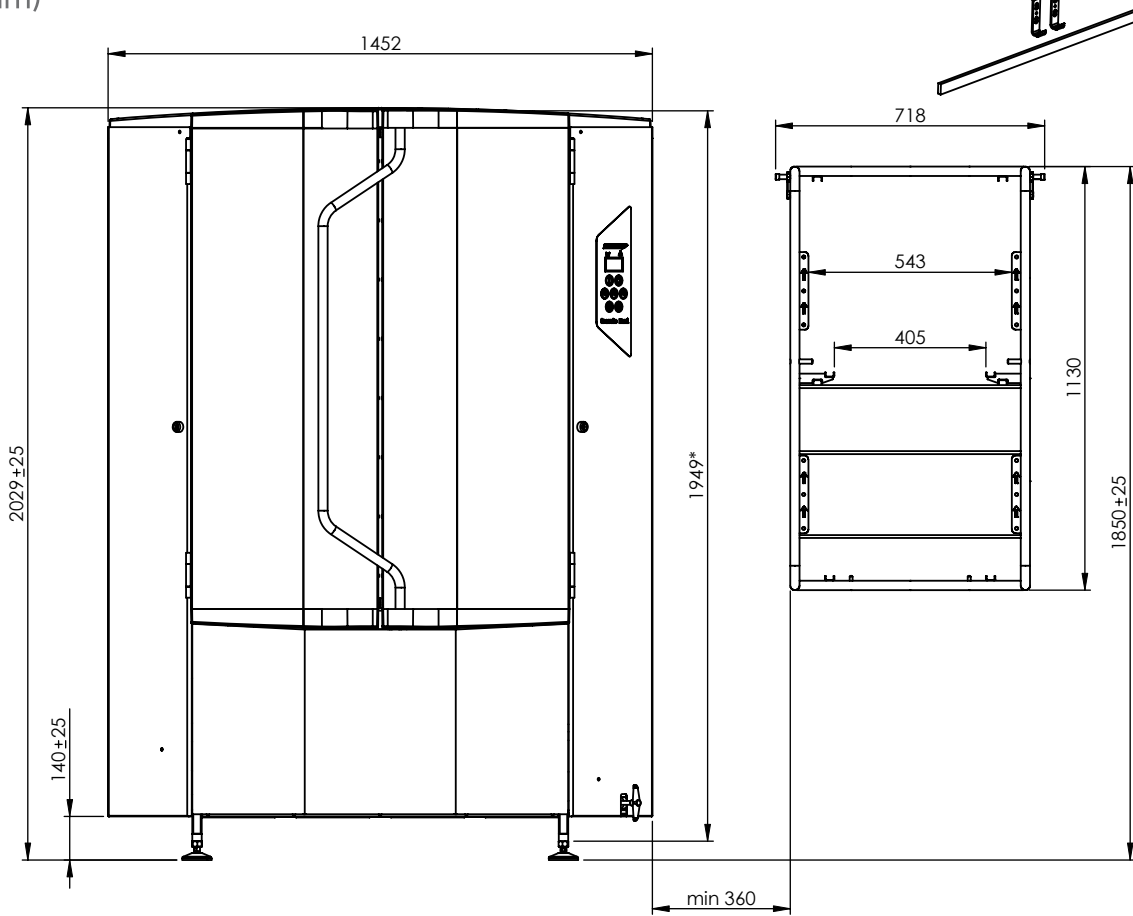

\* Minimum intake height (without roof and feet).  
 \*\* Minimum intake width, GD Min, (all loose parts dismantled).

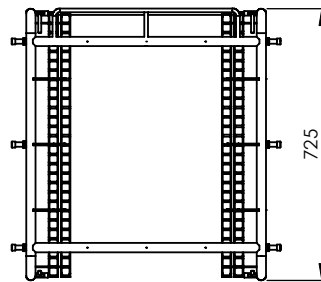

- A = Hot water 55-65 °C, 3-7 °dH
- B = Cold water 3-7 °dH
- C = Drain Ø 32 mm. 170 mm from floor. Horizontal pipe.
- D = Detergent connection
- E = Electrical connection